

河南万基2X660MW超临界机组增设0号高加热平衡图

初步设计仅供参考

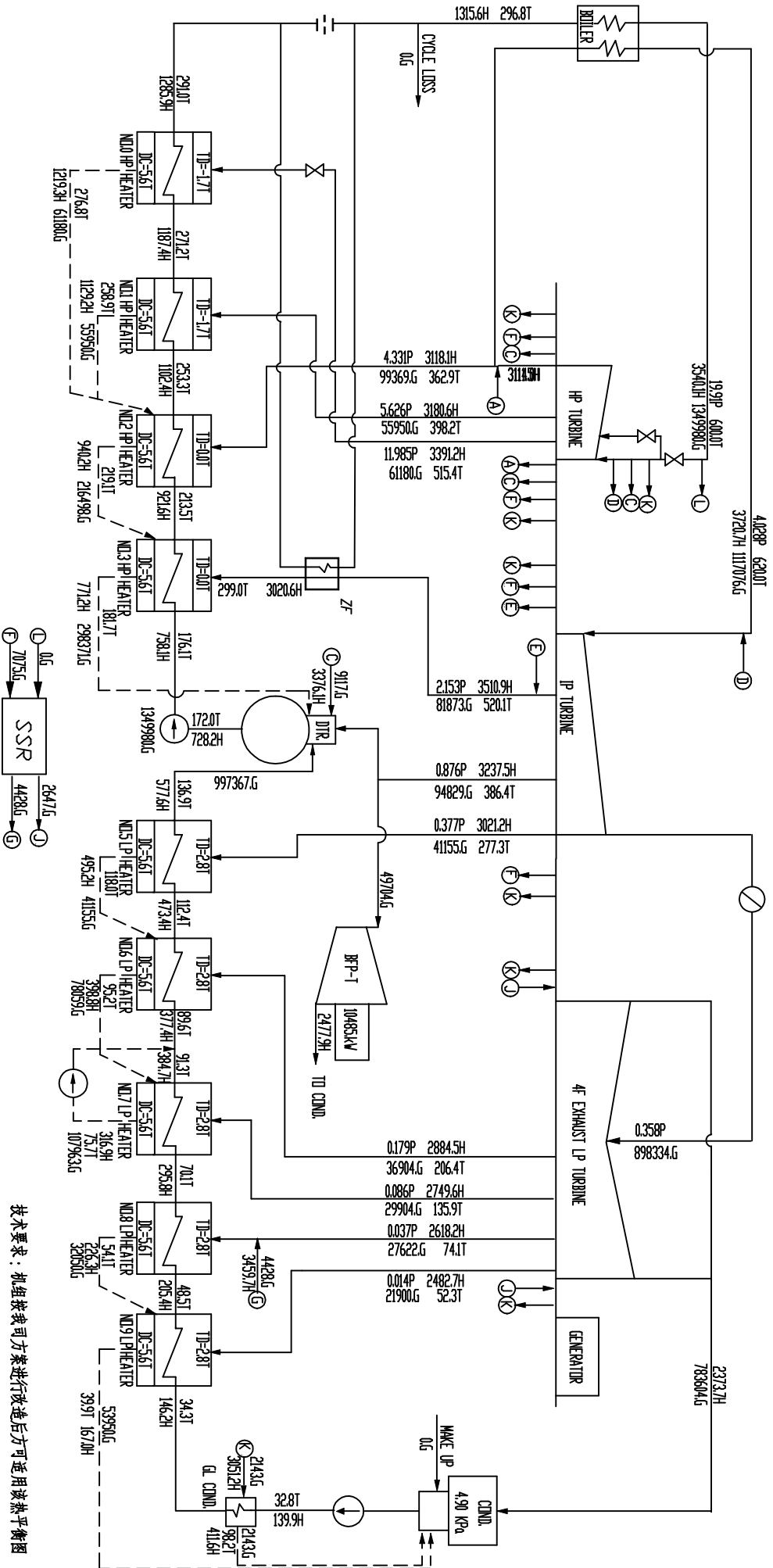

技术要求：机组按我司方案进行改造后方可适用该热平衡图

FLUID	G	kg/h
PRESSURE	P	MPa
TEMPERATURE	T	℃
ENTHALPY	H	KJ/KG



DN	DN	LOAD	75%THA 按0号高加工况	REMARK	
CHKD		HEAT RATE	495062 kW		
APPD		STEAM RATE	7426 kg/kWh		
		THROTTLING FLOW	1349980 kg/h		
		DWG NO.	FV-26055A001		